



STRETCH WRAPPER
MODEL: CSA 915

CSA 915 Save your Time

Compact, high performance rotating arm machine for wrapping pallets with stretch film.

Technical Characteristics

| | |
|--|--------------------------|
| Total power installed | 2.5 (kW) |
| Standard input voltage | 400V three-phase-50Hz-6A |
| Protection on electric system & motors | IP 54 |
| Max pallet dimensions | 1000 x 1200 mm |
| Standard pallet height | 2400 mm |
| Max capacity | 1500 Kg |
| Maximum rotation speed | 12 rpm |
| Production capacity per h | Up to 15 |
| Operating pressure | 6 bar pneumatic |

- Optionals
- Inox version.
 - Acid protection.
 - Integrated weighing systems.
 - Mast for loads up to 3000 mm high.
 - Film weight check.
 - Pallet holder presser.
 - Roping system.

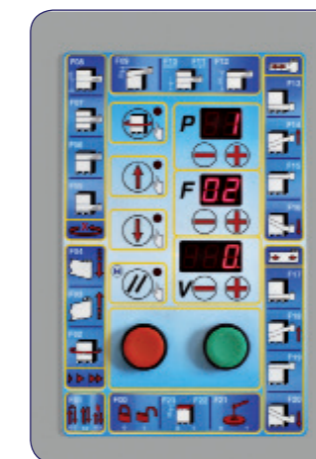
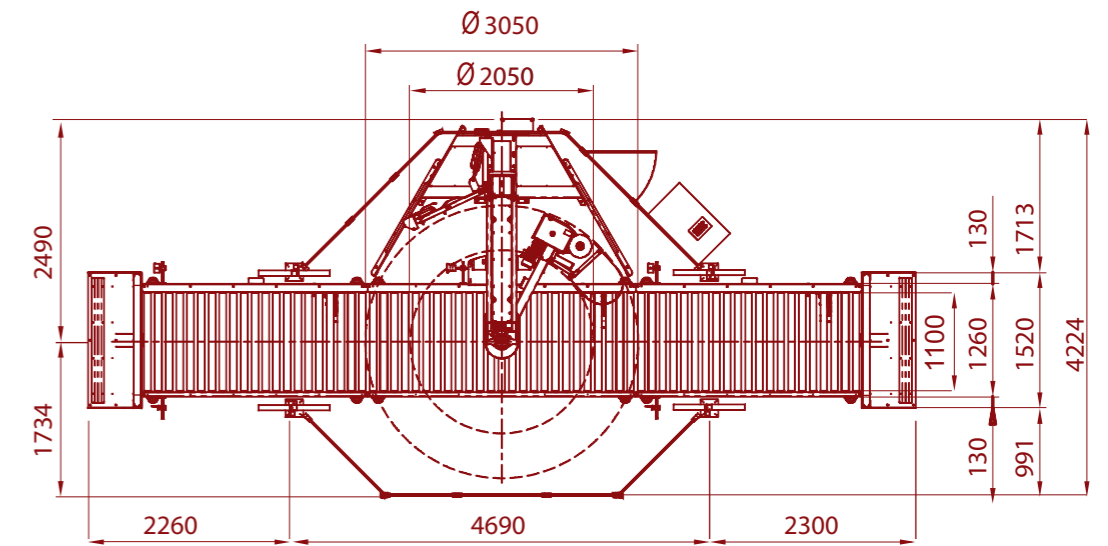

Control panel 99 programs easy-to-use.

Save your Money

Motorized pre-stretch system with 3 driven rollers electronically controlled with interchangeable ratios: 150 - 200 - 250%.

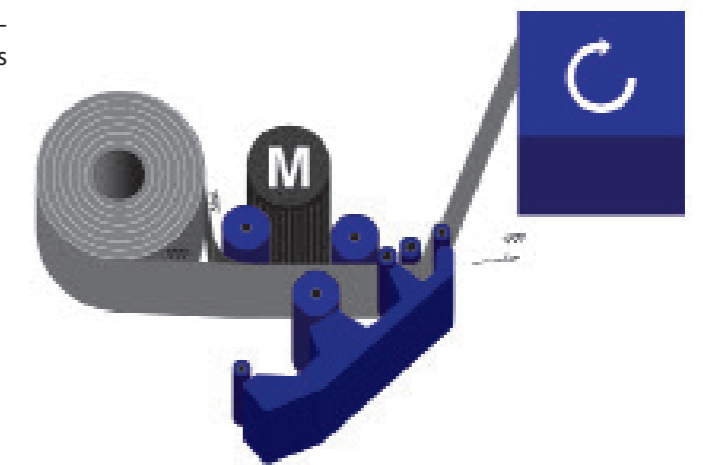

WWW.CYKLOP.NL
+31 384675800

CYKLOP Nederland BV
Benjamin Franklinstraat 5
8013 NC Zwolle
info@cyklop.nl

